

Front Bumper and Header 105 - FBR

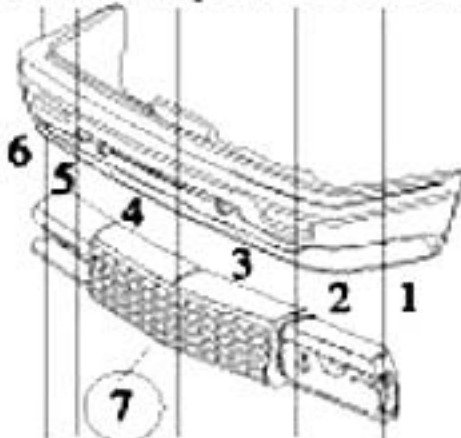

190 - RBR Rear Bumper and End Panel

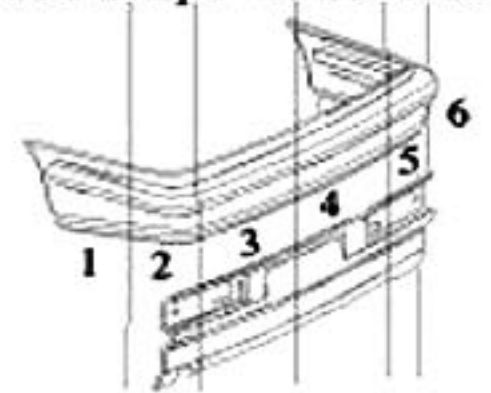

ARA Damage Locator

Bumpers and End Panels
only use #1 and #6 when
they wrap around the side

Fender 110 - FEN

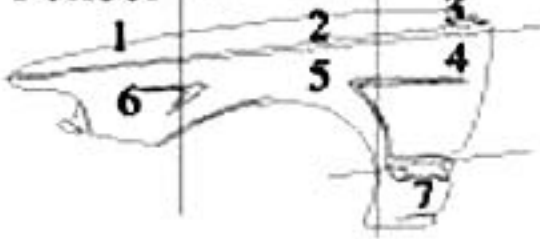

160 - QTR

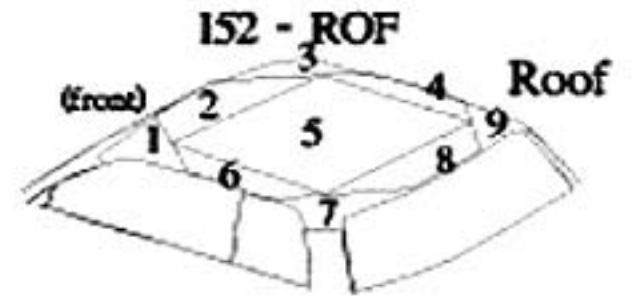
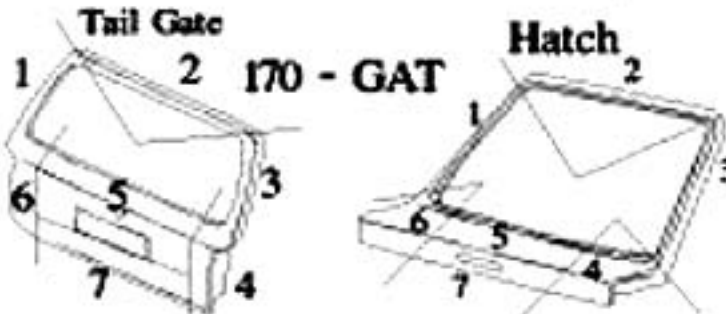
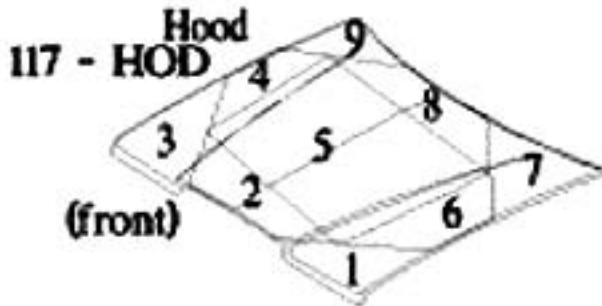
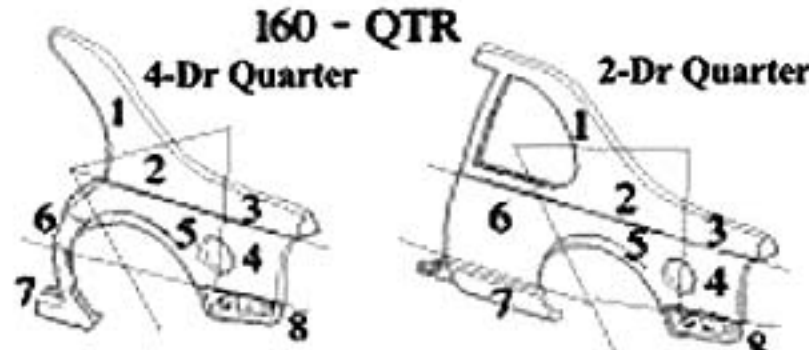

Dotted Lines in
Window Area for
Gates with Windows

Damage Locations always follow the same pattern: Front to back, top to bottom, left to right (as seen from driver's seat), in an "S" pattern, with locations for door handles and mirrors. Codes are location, damage, and hours. Example: "2D1" is a one hour dent in location 2. There may be a primary and secondary code per part, as in "2D1AS2". If there is no damage on a part the code is 000 (as in three zeros). Zero as a location indicates the entire panel, as in 0H4 (all over hail damage, 4 Hrs).

Damage Code Table

B = Burn	C = Crease	R = Rust on Surface
D = Dent	E = Bent	P = Parking Lot Dings
L = Lip	K = Buckle	S = Scratch - Surface Only
H = Hail	J = Rip or crack	T = Paint Problem
000 = No Damage (all zero)		